

# Test Report

No. 509 24575/2 Rev 1 e\*)



**Report date** 19. May 2003

**Client** OTTO - CHEMIE  
Hermann Otto GmbH  
Krankenhausstr. 14  
  
83413 Fridolfing

**Order description** Determination of the tensile strength of glued corner connections of aluminium profiles after 24 hours of curing time of the adhesive.

**Object** Adhesive: OTTOCOLL® P 520 identical with Novapur P 520  
Profile: Profil 166030, Royal S 65, Fa. Schüco  
Corner conn.: Aluminium - pressure casting

<b>Contents</b>	1	Definition of task
	2	Object
	3	Implementation
	4	Result
	5	Notes on the use of ift-test reports

\*) The test report No. 509 24575/2 dated 4 September 2001 has been corrected according to the new system designation. The number of the valid test report is 509 24575/2 Rev 1.  
The revision only concerns the change of system designation of the adhesive tested.  
This test report is a translation of test report no. 509 24575/2 Rev 1.

## 1 Definition of task

Hermann Otto GmbH, 83413 Fridolfing, instructed **ift** Rosenheim to examine the tensile strength of frame joints with glued corner connections using aluminium profiles. The tensile strength was determined after 24 hours of curing time.

## 2 Object

The Client provided **ift** with glued, mitre-jointed frame corners with the following data

Delivery of samples 23. August 2001

Test date 23 August 2001

**Adhesive** OTTOCOLL<sup>®</sup> P 520 identical with Novapur P 520 ,  
Component A: Charge Nr. A 1063821  
Component B: Charge Nr. B 1063831

**Aluminium-profile** Profile 166030, Royal S 65, Fa. Schüco, (figure 1)

**Corner connection** Aluminium - pressure casting, Schüco Royal S 65, Art. Nr. 216243 and 216236

The frame corners were glued in accordance with the instructions for use provided by the adhesive manufacturer without cleaning of surface in advance and without using primer.

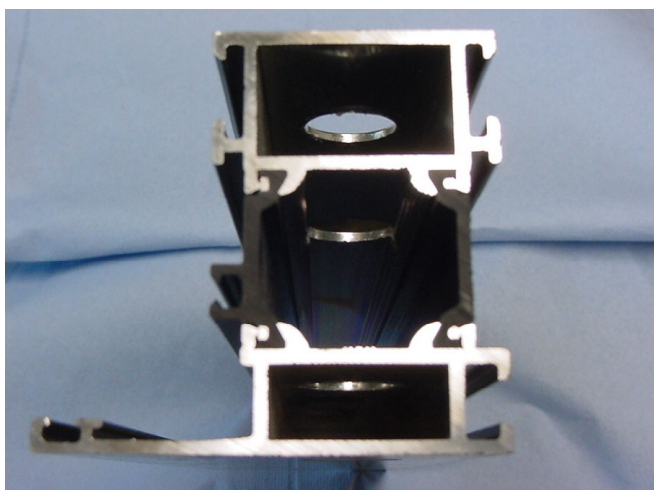

**Figure 1** Tested profile of system Royal S 65

### 3 Implementation

Before testing the tensile strength, the nails to fix the corner angle were removed so that only the gluing was effective, without any mechanical fixings. The tensile strength was tested in standard climate according to DIN 50014-23/50-2 with a constant forward movement speed of 2 mm/min. The test arrangement is shown in figure 1.

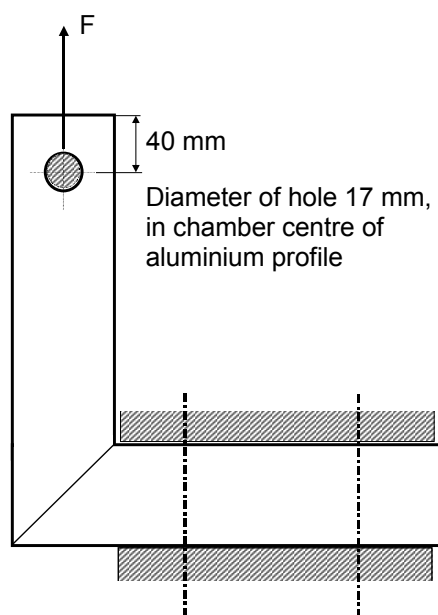

**Figure 2** Arrangement to test the tensile strength

### 4 Results

Table 1 summarises the values of tensile strength determined after 24 hours of curing time in standard climate 23/50-2.

**Table 1** Tensile strength after 24 h of curing time

Test specimen no.	maximum tensile strenght in N
1	14030
2	15935
3	11560
4	14820
5	14195
6	15580
7	12995
Mean value	14159
Standard deviation	1513
Variation coefficient in %	11

For all samples the type of failure was rupture of the corner connection (figure 3)

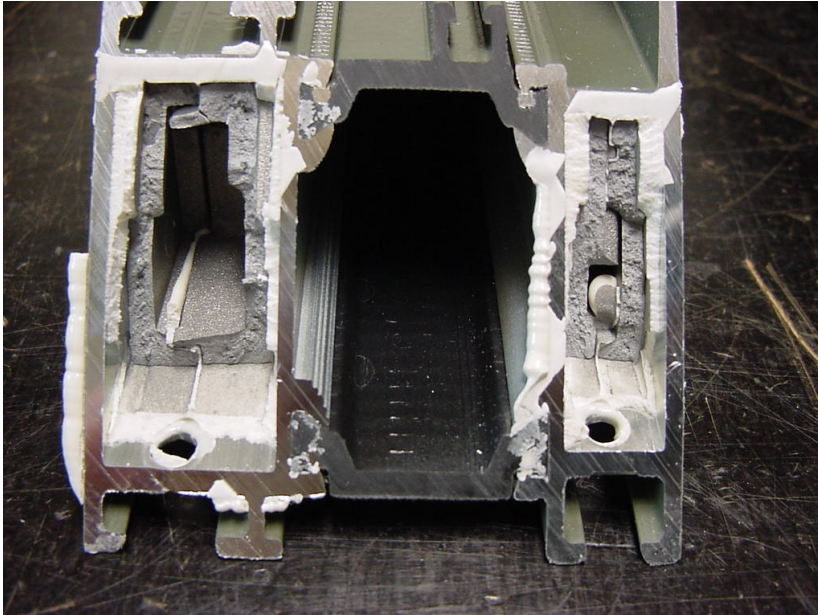

Figure 3 Type of failure at tensile test line described in figure 2

### Validity of test results

The values stated in this Test Report are exclusively related to the described and tested objects described in item 2.

## 5 Notes on the use of ift test reports

The enclosed **ift** notice "Conditions and notes for the use of ift test documents for advertising purposes and for publication of their content" lays down the rules on the use of the test reports.

The test report No. 509 24575/2 dated 4 September 2001 has been corrected according to the new system designation. The number of the valid test report is 509 24575/2 Rev 1.

The revision only concerns the change of system designation of the adhesive tested.

This test report is a translation of test report no. 509 24575/2 Rev 1.

ift Rosenheim

19. May 2003

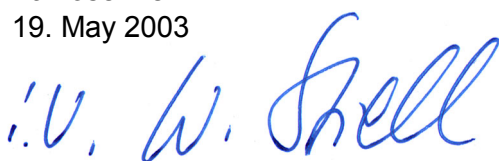

Dr. Helmut Hohenstein  
Director



i. A. Karin Lieb  
Head of Material Testing Department